



## Who we are

We provide modern and cost effective equipment ( heat, water meters, pumps, valves

Readout systems, Lora RF systems ) and automation and power distribution solutions.

Atlas Sayaç A.S. is located Turkey, and it occupies an area of 10.000 square meters.

Atlas company is an Turkish company that has been designing, producing and distributing instruments, pumps and valves solutions used for heating and cooling, for over 20 years.

The result of work of our engineers our company have own patents, inventions and industrial designs registered in Turkey.

Atlas company employs over 100 employees in Turkey. The yearly production currently exceeds 200,000 units putting Atlas in a leading position at Turkish level.

The product range includes heat and water meters, Readout systems ( Lora RF, GSM) Pumps, Heat Cost Allocators, Frequency Converters, Big Size Water meters, Irrigation System Valves, etc.

# Table of contents

|           |   |
|-----------|---|
| <b>4</b>  | Ultrasonic Heat Meters                              |
| <b>5</b>  | Singlejet Heat Meters                               |
| <b>6</b>  | Multijet Heat meters                                |
| <b>7</b>  | Cold /Hot Water Meters                              |
| <b>8</b>  | Ultrasonic Water Meters                             |
| <b>9</b>  | Ultrasonic Flow Meters                              |
| <b>10</b> | Heat Cost Allocator                                 |
| <b>11</b> | Thermostatic Radiator Valves                        |
| <b>12</b> | Dynamic Balance Valves                              |
| <b>13</b> | Prepaid Meters                                      |
| <b>14</b> | Circulation Pump                                    |
| <b>15</b> | Circulation Pump ECO                                |
| <b>16</b> | MBUS/ LoRa RF Concentrators/ Gateways               |
| <b>17</b> | ATLAS LoRa Lorawan Gateway                          |
| <b>18</b> | 3 way valves and actuators (DN20... DN200)          |
| <b>19</b> | Remote control Valve (dn20 to DN200)                |
| <b>20</b> | Ball Valve  |
| <b>21</b> | Gate Valve  |
| <b>22</b> | AC frequency Converters                             |
| <b>23</b> | Temperature Sensors ( PTC NTC Pt100, Pt1000, Pt500) |

# Ultrasonic Heat Meters

## Application

ATLAS UKM series is a high accurate meter for measuring consumption energy in heating and cooling systems in residential, and industrial facilities. Ultrasonic flow sensor, with brass/ plastic housing, is key part of device that ensures high precision, high measurement stability of meter regardless of its mounting position (horizontal/vertical). Besides it ensures insensitivity of device to magnetic field. Information from the meter can be read remotely by wire (M-Bus, LoRA RF, pulse/analog output) or wirelessly (LoRA RF 868 MHz), allowing cooperation of ATLAS CNV Concentrator and LoRa Gateway with different data reading systems and building automation.”

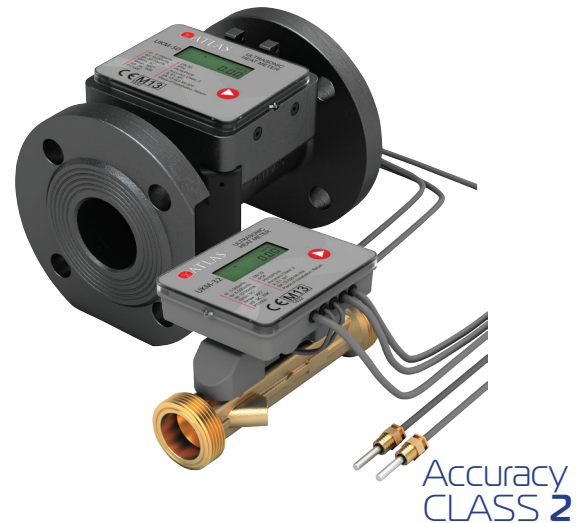

Approved according to the MID 2014/32/EU MI004



| Type    | DN [mm] | $q_p$ [m <sup>3</sup> /h] | $q_i$ [m <sup>3</sup> /h] | Length [mm] | Height [mm] | Width [mm] |
|---------|---------|---------------------------|---------------------------|-------------|-------------|------------|
| UKM 15  | 15      | 0,60 / 1,50               | 0,012 / 0,03              | 110         | 94          | 83         |
| UKM 20  | 20      | 2,50                      | 0,05                      | 130         | 94          | 83         |
| UKM 25  | 25      | 3,50                      | 0,07                      | 180         | 94          | 83         |
| UKM 32  | 32      | 6,00                      | 0,06                      | 180         | 100         | 83         |
| UKM 40  | 40      | 10,00                     | 0,10                      | 200         | 120         | 83         |
| UKM 50  | 50      | 15,00                     | 0,15                      | 200         | 165         | 165        |
| UKM 65  | 65      | 25,00                     | 0,25                      | 200         | 185         | 185        |
| UKM 80  | 80      | 40,00                     | 0,40                      | 220         | 200         | 200        |
| UKM 100 | 100     | 60,00                     | 0,60                      | 250         | 220         | 220        |
| UKM 125 | 125     | 100,00                    | 1,00                      | 250         | 250         | 250        |
| UKM 150 | 150     | 150,00                    | 1,50                      | 300         | 285         | 285        |
| UKM 200 | 200     | 250,00                    | 2,50                      | 350         | 340         | 340        |
| UKM 250 | 250     | 400,00                    | 4,00                      | 450         | 405         | 405        |
| UKM 300 | 300     | 560,00                    | 5,60                      | 500         | 460         | 460        |

## Product features

- Temperature range 5...130°C.
- Nominal pressure: PN16
- Meter protection rating: IP65
- Energy units: kWh, MWh, Gcal, GJ \*Optional
- Work with systems containing water
- Easy to read 8 digit display, with symbols indicating operation state of meter, operated by a single button
- Some models have rotatable by 180° calculator with wall-mount possibility.
- Battery powered (battery lifetime up to 10 years)
- Integrated pulse outputs for energy and volume.

# Singlejet Heat Meters

## Application

Seres and SJM Singlejet Series heat meters is a high accurate meter for measuring consumption energy in heating and cooling systems in residential, and industrial facilities. Singlejet/ Multijet flow sensor, with brass/ plastic housing, is key part of device that ensures high precision, high measurement stability of meter regardless of its mounting position (horizontal/ vertical). Besides it ensures insensitivity of device to magnetic field. Information from the meter can be read remotely by wire (M-Bus, LoRA RF, pulse/analog output) or wirelessly (LoRA RF 868 MHz), allowing cooperation of ATLAS CNV COncentrator and LoRa Gateway with different data reading systems and building automation.”



Approved according to the MID 2014/32/EU MI004



| Type        | DN [mm] | $q_p$ [m <sup>3</sup> /h] | $q_i$ [m <sup>3</sup> /h] | Length [mm] | Height [mm] | Width [mm] |
|-------------|---------|---------------------------|---------------------------|-------------|-------------|------------|
| SERES SOLID | 15      | 0,60 / 1,50               | 0,012 / 0,03              | 110         | 107         | 84         |
| SERES SOLID | 20      | 2,50                      | 0,05                      | 130         | 107         | 84         |
| SERES SOLID | 25      | 3,50                      | 0,07                      | 180         | 107         | 84         |
| SJM 15      | 15      | 1,50                      | 0,03                      | 110         | 81          | 70         |
| SJM 20      | 20      | 2,50                      | 0,05                      | 130         | 81          | 70         |
| SJM 25      | 25      | 3,50                      | 0,07                      | 180         | 81          | 70         |

## Product features

- Temperature range 5...130°C.
- Nominal pressure: PN16
- Meter protection rating: IP65
- Energy units: kWh, MWh, Gcal, GJ \*Optional
- Work with systems containing water
- Easy to read 8 digit display, with symbols indicating operation state of meter, operated by a single button
- Some models have rotatable by 180° calculator with wall-mount possibility.
- Battery powered (battery lifetime up to 10 years)
- Integrated pulse outputs for energy and volume.
- High Accurate readings (Class 2)
- Fully resistant on the external magnetic field
- Brass / Composite body alternative
- PT100/PT500/PT1000 alternative

# Multijet Heat Meters

## Application

MKM Multijet series heat meters is a high accurate meter for measuring consumption energy in heating and cooling systems in residential, and industrial facilities. Singlejet/ Multijet flow sensor, with brass/ plastic housing, is key part of device that ensures high precision, high measurement stability of meter regardless of its mounting position (horizontal/vertical). Besides it ensures insensitivity of device to magnetic field. Information from the meter can be read remotely by wire (M-Bus, LoRA RF, pulse/analog output) or wirelessly (LoRA RF 868 MHz), allowing cooperation of ATLAS CNV COncentrator and LoRa Gateway with different data reading systems and building automation.”

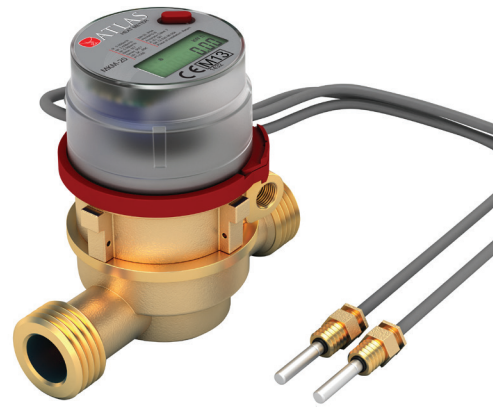

Accuracy  
CLASS 2

Approved according to the MID 2014/32/EU MI004



| Type   | DN [mm] | $q_p$ [m <sup>3</sup> /h] | $q_i$ [m <sup>3</sup> /h] | Length [mm] | Height [mm] | Width [mm] |
|--------|---------|---------------------------|---------------------------|-------------|-------------|------------|
| MKM 15 | 15      | 0,60 / 1,50               | 0,012 / 0,03              | 110         | 120         | 70         |
| MKM 20 | 20      | 2,50                      | 0,05                      | 130         | 120         | 70         |
| MKM 25 | 25      | 3,50                      | 0,07                      | 180         | 120         | 70         |

## Product features

- Temperature range 5...130°C.
- Nominal pressure: PN16
- Meter protection rating: IP65
- Energy units: kWh, MWh, Gcal, GJ \*Optional
- Work with systems containing water
- Easy to read 8 digit display, with symbols indicating operation state of meter, operated by a single button
- Some models have rotatable by 180° calculator with wall-mount possibility.
- Battery powered (battery lifetime up to 10 years)
- Integrated pulse outputs for energy and volume.
- High Accurate readings (Class 2)
- Fully resistant on the external magnetic field
- Brass / Composite body alternative
- PT100/PT500/PT1000 alternative



# Cold / Hot Water Meters (Electronic Water Meter)

## Application

ATLAS EC20/EH20 series is a high accurate meter for measuring consumption water quantity in water distribution systems in residential, and industrial facilities. Singlejet flow sensor, with brass/ plastic housing, is key part of device that ensures high precision, high measurement stability of meter regardless of its mounting position (horizontal/vertical). Besides it ensures insensitivity of device to magnetic field. Information from the meter can be read remotely by wire (M-Bus, LoRa RF, pulse/analog output) or wirelessly (LoRa RF 868 MHz), allowing cooperation of ATLAS CNV Concentrator and LoRa Gateway with different data reading systems and building automation.”



Accuracy  
CLASS 2

Approved according to the MID 2014/32/EU MI001



| Type  | Q <sub>3</sub> /Q <sub>1</sub> | DN [mm] | Q <sub>4</sub> [m <sup>3</sup> /h] | Q <sub>3</sub> [m <sup>3</sup> /h] | Q <sub>2</sub> [m <sup>3</sup> /h] | Q <sub>1</sub> [m <sup>3</sup> /h] | Length [mm] | Height [mm] | Width [mm] |
|-------|--------------------------------|---------|------------------------------------|------------------------------------|------------------------------------|------------------------------------|-------------|-------------|------------|
| EC 15 | R100                           | 15      | 2,00                               | 1,60                               | 0,025                              | 0,016                              | 110         | 81          | 70         |
| EC 15 | R100                           | 15      | 3,125                              | 2,50                               | 0,04                               | 0,025                              | 110         | 81          | 70         |
| EC 20 | R100                           | 20      | 3,125                              | 2,50                               | 0,04                               | 0,025                              | 130         | 81          | 70         |
| EC 20 | R100                           | 20      | 5,00                               | 4,00                               | 0,064                              | 0,04                               | 130         | 81          | 70         |
| EC 25 | R100                           | 25      | 7,875                              | 6,30                               | 0,10                               | 0,063                              | 180         | 81          | 70         |
| EH 15 | R100                           | 15      | 2,00                               | 1,60                               | 0,025                              | 0,016                              | 110         | 81          | 70         |
| EH 15 | R100                           | 15      | 3,125                              | 2,50                               | 0,04                               | 0,025                              | 110         | 81          | 70         |
| EH 20 | R100                           | 20      | 3,125                              | 2,50                               | 0,04                               | 0,025                              | 130         | 81          | 70         |
| EH 20 | R100                           | 20      | 5,00                               | 4,00                               | 0,064                              | 0,04                               | 130         | 81          | 70         |
| EH 25 | R100                           | 25      | 7,875                              | 6,30                               | 0,10                               | 0,063                              | 180         | 81          | 70         |

## Product features

- Temperature range T30/90°C for EH series, T50 for EC series.
- Nominal pressure: PN16
- Meter protection rating: IP65
- Work with systems containing water
- Easy to read 8 digit display, with symbols indicating operation state of meter, operated by a single button
- Some models have rotatable by 180° calculator with wall-mount possibility.
- Battery powered (battery lifetime up to 11 years)
- Integrated pulse outputs for volume.
- Can be installed in any orientation
- Fully AMR compatible



# Ultrasonic Water Meters

## Application

ATLAS USM15.....USM300 series is a high accurate meter for measuring consumption water quantity in water distribution systems in residential, and industrial facilities. Ultrasonic flow sensor, with brass/ Cast Iron housing, is key part of device that ensures high precision, high measurement stability of meter regardless of its mounting position (horizontal/vertical). Besides it ensures insensitivity of device to magnetic field. Information from the meter can be read remotely by wire (M-Bus, LoRA RF, pulse/analog output) or wirelessly (LoRA RF 868 MHz), allowing cooperation of ATLAS CNV COncentrator and LoRa Gateway with different data reading systems and building automation.

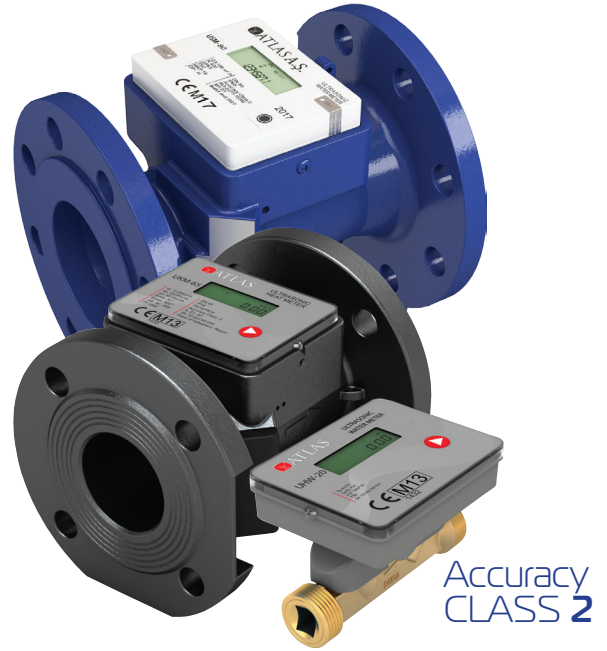

Approved according to the MID 2014/32/EU MI001



| Type    | DN [mm] | Q <sub>3</sub> /Q <sub>1</sub> | Q <sub>4</sub> [m <sup>3</sup> /h] | Q <sub>3</sub> [m <sup>3</sup> /h] | Q <sub>2</sub> [m <sup>3</sup> /h] | Q <sub>1</sub> [m <sup>3</sup> /h] | Length [mm] | Height [mm] | Width [mm] |
|---------|---------|--------------------------------|------------------------------------|------------------------------------|------------------------------------|------------------------------------|-------------|-------------|------------|
| USM 15  | 15      | R400                           | 2,000 / 3,125                      | 1,600 / 2,500                      | 0,006 / 0,010                      | 0,004 / 0,006                      | 110         | 94          | 83         |
| USM 20  | 20      | R400                           | 3,125 / 5,000                      | 2,500 / 4,000                      | 0,010 / 0,016                      | 0,006 / 0,010                      | 130         | 94          | 83         |
| USM 25  | 25      | R400                           | 7,875                              | 6,300                              | 0,025                              | 0,015                              | 180         | 94          | 83         |
| USM 32  | 32      | R400                           | 12,500                             | 10,000                             | 0,040                              | 0,025                              | 180         | 100         | 83         |
| USM 40  | 40      | R400                           | 31,250                             | 25,000                             | 0,100                              | 0,063                              | 200         | 120         | 83         |
| USM 50  | 50      | R400                           | 50,000                             | 40,000                             | 0,160                              | 0,100                              | 200         | 165         | 165        |
| USM 65  | 65      | R400                           | 78,750                             | 63,000                             | 0,250                              | 0,160                              | 200         | 185         | 185        |
| USM 80  | 80      | R400                           | 125,000                            | 100,000                            | 0,400                              | 0,250                              | 220         | 200         | 200        |
| USM 100 | 100     | R400                           | 200,000                            | 160,000                            | 0,640                              | 0,400                              | 250         | 220         | 220        |
| USM 125 | 125     | R400                           | 200,000                            | 160,000                            | 0,640                              | 0,400                              | 250         | 250         | 250        |
| USM 150 | 150     | R400                           | 312,500                            | 250,000                            | 1,000                              | 0,630                              | 300         | 285         | 285        |
| USM 200 | 200     | R400                           | 500,000                            | 400,000                            | 1,600                              | 1,000                              | 350         | 340         | 340        |
| USM 250 | 250     | R400                           | 787,500                            | 630,000                            | 2,520                              | 1,580                              | 450         | 405         | 405        |
| USM 300 | 300     | R400                           | 1.250,00                           | 1.000,00                           | 4,000                              | 2,500                              | 500         | 460         | 460        |

## Product features

- Temperature range T30/90°C.
- Nominal pressure: PN16
- Meter protection rating: IP68
- Work with systems containing water
- Easy to read 8 digit display, with symbols indicating operation state of meter, operated by a single button
- Some models have calculator with wall-mount possibility.
- Battery powered (battery lifetime up to 11 years)
- Integrated pulse outputs for volume.



# Ultrasonic Flow Meters

## Application

Water

Hot water / cooling systems

Oil and liquefied gases

## Benefits

- Design for industrial applications
- No pressure drop
- Conductive or non-conductive
- Reliable and accurate flow measurements
- Long-time stability
- insensitivity of device to magnetic field



| Type  | DN [mm] | Min. Flow [m <sup>3</sup> /h] | Max. Flow [m <sup>3</sup> /h] | Length [mm] | Height [mm] | Width [mm] |
|-------|---------|-------------------------------|-------------------------------|-------------|-------------|------------|
| DN50  | 40      | 0,1                           | 40                            | 50          | 50          | 300        |
| DN65  | 63      | 0,1575                        | 63                            | 78,75       | 65          | 300        |
| DN80  | 100     | 0,25                          | 100                           | 125         | 80          | 300        |
| DN100 | 160     | 0,4                           | 160                           | 200         | 100         | 350        |
| DN125 | 250     | 0,625                         | 250                           | 312,5       | 125         | 350        |
| DN150 | 400     | 1                             | 400                           | 500         | 150         | 400        |
| DN200 | 630     | 1,575                         | 630                           | 787,5       | 200         | 400        |
| DN250 | 1000    | 2,5                           | 1000                          | 1250        | 250         | 500        |
| DN300 | 1600    | 4                             | 1600                          | 2000        | 300         | 500        |

## Product features

- **Output : MODBus, ProfiBus DP, 4-20 mA HART, 0-10V, Pulse/**
- frequency/switch output/Relay
- Protection Class : IP68
- Measuring Cycle : 0,2sn
- Connection : Flange
- Accuracy : 0,2%
- Possibility : **GSM/GPRS** data transmission
- Flow : Bidirectional flow measurement
- Material : Steel, 304-316 Optional
- Humidity : 0-95%
- High temperature versions available
- Bi-directional flow measurement over a wide dynamic range
- Various digital communication options

# Heat Cost Allocator

COST ALLOCATOR Unical

Electronic double-sensored heating cost allocator

Heating cost allocator Unical designed for monthly calculations of heating consumption costs in the rooms with heating systems. Preferable application range – horizontal or vertical heating systems with one or two pipes with an average minimum heating transmitter temperature equal or higher than 35°C and at a maximum equal or lower than 90°C.



| Technical Parameters        | ATLAS Unical                  |
|-----------------------------|-------------------------------|
| Reading range in open space | < 250 m                       |
| Data protocol format        | LCD / Wireless M-Bus/ LoRa RF |
| Frequency range             | 868 MHz                       |
| Output power                | < 5 mW                        |
| Protection degree           | IP42                          |
| Weight                      | 0,076 kg                      |

## Product features

- Wireless data transmission system realised by: direct reading through the reader and radio interface for remote reading outside the room with installed cost allocators.
- Cost allocator is equipped with ergonomically placed LCD display that allows the user to comfortably read the current values of heat consumption. Moreover, these data are registered in internal memory module
- Installation and configuration of additional equipment is not required. The cost allocator operates based on the software that considers real heat consumption in the given apartment.
- Any unauthorised manipulation (breaking the electronic seal) is registered with the exact date of this occurrence. The information about manipulation trial is sent together with the next radio reading.
- Data reading with PDA or by the stationary network of data readings
- Elimination of eventual mistakes casued by the human factor
- Easy data reading from the hard to reach installed appliances
- Data reading is fully resistant for any interference from the magnetic field

# Thermostatic Radiator Valves

## Application

Unical DN15 TRV

- Unical R 1/2”F
- Relevant standard : EN 215
- Working pressure : 10 bar
- Maximum working temperature : 120°C
- Setting range : +5° , +29°C
- Nominal flow rate : qmNH=265kg/h (±)
- Hysteresis : C=0,4K
- Differential pressure influence : D=0,4K
- Water temperature influence : W=0,6K
- Response time : Z=23 min.



| Connection Size                   |         |
|-----------------------------------|---------|
| Model                             | Size    |
| Thermostatic head                 | M30x1,5 |
| Thermostatic valves DN15 straight | 1/2"    |
| Thermostatic valves DN15 angled   | 1/2"    |

## Packaging specifications:

| Model       | Box size(mm) | Carton size(cm) | PCS/CTN | G.W.(kg) | Pallet size(cm) | PCS/each pallet |
|-------------|--------------|-----------------|---------|----------|-----------------|-----------------|
| Unical DN15 | 55x55x95     | 57.5X30X21      | 100     | 16       | 92X118X115      | 3000            |

Ensures optimal comfort at home, room by room.

Atlas radiator thermostats help people to obtain comfort in their homes. By maintaining constant desired room temperatures, individually or room by room, and by helping to reduce energy consumption.

They can save approximately 20% compared to a manually operated valve due to utilization of free heat gains and constant room temperature.

# Dynamic Balance Valves

## Application

ATLAS ADP Dynamic Balance Valve Series is designed for domestic heating/ cooling systems, to reduce water and save energy.

Balancing is based on the placement of valves on the circuit, in order to control flow. It is essential if the system is subject to variable flow rates. It adjusts the flow rate necessary for each branch or device, allowing them to deliver the power for which they have been calculated.

Reduces noise in the system, particularly in high-rise constructions, by controlling excessive flow rates. Allows partial closing of projects and system maintenance while working.

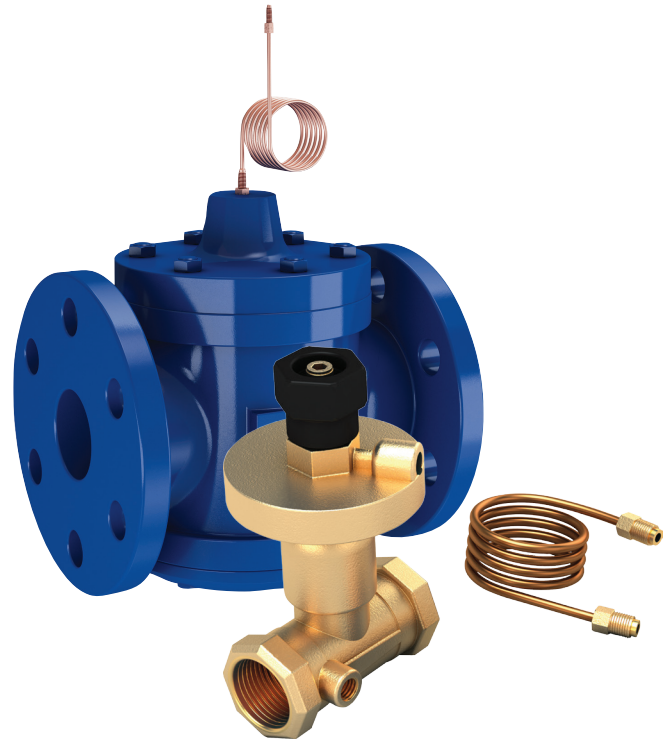

| Type    | DN [mm] | K <sub>vs</sub> Value [m³/h] | PN [bar] | Max. Pressure Difference [bar] | Max. Differential Pressure [kPa] | Length [mm] | Height [mm] |
|---------|---------|------------------------------|----------|--------------------------------|----------------------------------|-------------|-------------|
| ADP 20  | 20      | 1,2-1,6                      | 25       | 4,5                            | 5-25                             | 70          | 104         |
| ADP 25  | 25      | 1,2-8,6                      | 25       | 4,5                            | 5-25                             | 120         | 160         |
| ADP 32  | 32      | 1,3-13                       | 25       | 4,5                            | 5-25                             | 180         | 174         |
| ADP 40  | 40      | 1,2-1,6                      | 25       | 4,5                            | 5-25                             | 200         | 220         |
| ADP 50  | 50      | 2,2-39                       | 25       | 4,5                            | 5-25                             | 230         | 240         |
| ADP 65  | 65      | 2,2-58                       | 25       | 4,5                            | 20-80                            | 290         | 300         |
| ADP 80  | 80      | 2,8-80                       | 25       | 4,5                            | 20-80                            | 310         | 310         |
| ADP 100 | 100     | 2,2-58                       | 25       | 4,5                            | 20-80                            | 350         | 375         |

## Features:

- Easy, fast and flexible HVAC system design
- Fast installation and easy setting
- Lower commissioning cost - no need for
- Faster project with staged handover Perfect balance at all loads
- Guaranteed flow and  $\Delta p$  for users
- No problems caused by poor designed/
- Unoccupied zones do not impact other
- Flow verification and easy troubleshooting
- No electric power required
- Longer life for thermostatic control valves

# Prepaid Meters

## Application

Adopts one touch less card “Separate” and “integrated” meter are available Different price can be set in different meter Beep alarm for low credit In this system, one water meter can work for many different IC card. When consumers insert the card in a meter, the water will flow out and the water quantity in card will be deducted correspondingly. This system can be used in public areas



Accuracy  
CLASS 2

| Type     | Dynamic range | $q_p$<br>[m <sup>3</sup> /h] | $q_i$<br>[m <sup>3</sup> /h] | DN<br>[mm] | Length<br>[mm] | Height<br>[mm] | Width<br>[mm] |
|----------|---------------|------------------------------|------------------------------|------------|----------------|----------------|---------------|
| USM 20-P | R - 400       | 4                            | 0,01                         | 20         | 195            | 96             | 100           |

## Features:

- Class 2
- DN15, 20 and 25
- Integrated low power bistable latched valve
- Potted electronics making meter water resistant in humid and tropical environments
- Low credit warning
- Over 10 years' data retention in absence of power
- Prepared for AMR functions with LoRa RF, MBUS, (optional)
- MID approved
- Supports LoRaWan and Wireless MBUS Protocols simultaneously
- Ultrasonic principle assures very high sensivity even at low flow
- No measurement of air, Reverse flow detection
- Can be mounted all positions desired



# Circulation Pump

ATLAS VFPUMP series circulation pump designed for

- Heating / Cooling systems
- Air conditioning and cooling systems
- Domestic water systems
- Ground-source heat pump systems
- Solar heating systems



| Type      | DN [mm] | Power (Watt) | H <sub>max</sub> [m] | Q <sub>max</sub> [m <sup>3</sup> /h] | Length [mm] | Height [mm] |
|-----------|---------|--------------|----------------------|--------------------------------------|-------------|-------------|
| VFPUMP 25 | 25      | 18-93        | 10                   | 12                                   | 130         | 180         |
| VFPUMP 32 | 32      | 33-245       | 14                   | 22                                   | 180         | 200         |
| VFPUMP 40 | 40      | 58-515       | 18                   | 22                                   | 250         | 310         |
| VFPUMP 50 | 50      | 99-890       | 25                   | 32                                   | 280         | 320         |
| VFPUMP 65 | 65      | 132-1180     | 25                   | 38                                   | 340         | 350         |

ATLAS VFPUMP series have two different type motor series .

## Asynchronous circulator series

- Standard model
- Integrated Frequency control system

### Frequency Control Model Features :

- AUTOADAPT
- FLOWADAPT and FLOWLIMIT
- Optional Constant temperature control
- Not need external motor protection
- Low energy consumption
- Simple installation
- Minimal maintenance and long life
- User interface and LCD display
- Optional heat energy meter function
- Range is available for system pressures of 6, 10 and 16 bar

### Standard Model Features :

- Simple Installati, on
- Minimal maintenance and long life
- Range is available for system pressures of, 6, 10 and 16 bar

# Circulation Pump ECO

ATLAS VFPUMP ECO series circulation pump designed for

- Heating / Cooling systems
- Air conditioning and cooling systems
- Domestic water systems
- Ground-source heat pump systems
- Solar heating systems

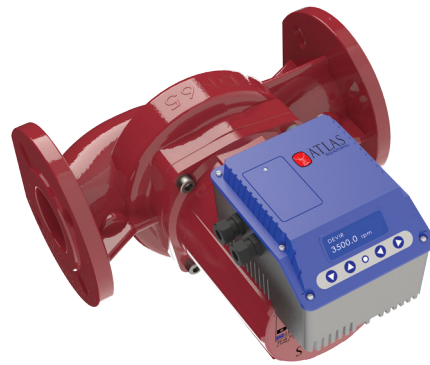

| Type       | DN [mm] | Power (Watt) | H <sub>max</sub> [m] | Q <sub>max</sub> [m <sup>3</sup> /h] | Length [mm] | Height [mm] |
|------------|---------|--------------|----------------------|--------------------------------------|-------------|-------------|
| ECOPUMP 25 | 25      | 18-93        | 10                   | 12                                   | 130         | 180         |
| ECOPUMP 32 | 32      | 33-245       | 14                   | 22                                   | 180         | 200         |
| ECOPUMP 40 | 40      | 58-515       | 18                   | 22                                   | 250         | 310         |
| ECOPUMP 50 | 50      | 99-890       | 25                   | 32                                   | 280         | 320         |
| ECOPUMP 65 | 65      | 132-1180     | 25                   | 38                                   | 340         | 350         |

ATLAS VFPUMP ECO series have two different type motor series. ATLAS VF PUMP ECO series have high efficient permanent magnet motor.

## Synchronous circulator series

- Permanent magnet series Integrated Frequency Control System

### Features :

- AUTOADAPT
- FLOWADAPT and FLOWLIMIT
- Optional Constant temperature control
- Not need external motor protection
- Low energy consumption
- Simple installation
- Minimal maintenance and long life
- User interface and LCD display
- Optional heat energy meter function
- Range is available for system pressures of 6, 10 and 16 bar

### Standard Model Features :

- Simple Installati, on
- Minimal maintenance and long life
- Range is available for system pressures of, 6, 10 and 16 bar



# MBUS/ LoRa RF Concentrators/ Gateways

## ATLAS CNV Mbus/ GSM concentrator:

- Read up to 250 device by M-BUS interface
- Protecting system for short circuit and overcurrent
- Warning system by light and buzzer
- Sleeping mode for preventing energy loss
- Supports RS232 and USB 2.0
- Supports from 300 baud up to 19.200 baud
- Works between -20 °C and +70 °C
- Produced according to the requirements of TS EN 1434-3 and TS EN 13757-2 standard systems
- It is possible to integrate a GSM modem to CNV250



## TECHNICAL DETAILS

- Supports all brand and model meters of which are produced according the requirements of EN 1434 Standards
- Active logout protection. It is not affected from unexpected situations of M-BUS system by its short circuit and overcurrent protection system.
- When CNV250 faces with short circuit, it warns the user by its led lights and buzzer. At the same time it keeps the line in quarantine to protect itself and meters.
- CNV250 keeps itself at energy save mode if it is not used. By the way it saves energy and it protects meters from the effects of noise. It keeps M-Bus line neutral to protect it from unexpected situations like short circuit.
- By its USB 2.0 output it can be connected to the computer directly without any convertor devices.
- It prevents the noise at line caused by foreign sources by its filtering system. USB port is totally insulated as galvanic. Even high voltage is applied to the M-Bus line, the computers connected to the convertor are not affected and damaged.
- The meters can be connected to the same line by 2 cables without any direction difference
- The cable length can be made longer up to 1500m without any additional device

# ATLAS LoRa Lorawan Gateway

## Application

- Application
- Smart city
- Smart Metering ( Water, Electric, Gas meter )
- Agricultural Monitoring
- Irrigation control
- Internet of Things (IoT)
- M2M
- Wireless Sensors
- Wireless Alarm and Security Systems



| Type                    | Input voltage       | Communication              | Frequency Range | Operating Frequency  | Communication Distance | Max TX Power | Max RX Sensitivity | Channel Output              | Width  | Length | Height |
|-------------------------|---------------------|----------------------------|-----------------|--|------------------------|--------------|--------------------|-----------------------------|--------|--------|--------|
| ATLAS LoRa Gateway LR-1 | 12-24 Volt, 2 Amper | Gsm, Ethernet, Rs485, Wifi | 433-923 MHz     | EU433, CN470-510, CN779-787, EU863-870, US902-928, AU915-928, AS923, KR920-923 | (Outdoor) 15 KM        | 25 dBm       | -140 dBm           | 7 LoRa Output, 1 FSK Output | 157 mm | 91 mm  | 58 mm  |

## ATLAS LoRa/ LoRaWAN Gateway specifications :

- Product Module: LoRaWan gateway
- LoRa long range module technology
- Half-duplex
- Simultaneously receive LoRa packets
- Dual digital Tx & Rx radio front-end
- Dynamic data-rate adaptation (ADR)
- Multi LoRa Spreading Factor
- Maximum 10 channels
- 8 x Multi SF LoRa channels (SF7 to SF12 with 125kHz Bandwidth)
- 1 x LoRa channel (Bandwidth 125/250/500kHz)
- 1 x FSK channel

## 3 way valves and actuators (DN20... DN200)

- The body is made from GGG40 cast iron \_  
Motor Shaft connections are Stainless steel \_  
Full compatibility with Atlas Ecopanel
- Full compatibility with Atlas Valve Actuator  
Actuator
- Ability to work with different brands and  
models of motor drives and ports compatibility  
\_ 90° rotation angle \_ Flanged connection  
PN6/PN10/PN16 \_ Pressure class PN6 \_ Can  
be produced from DN20 up to DN200

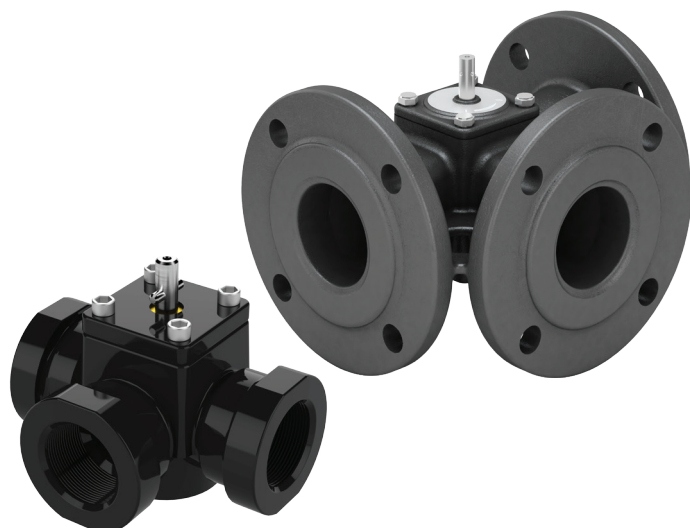

| Type    | KVS    | Connection   | Length (mm) | Width (mm) | Height (mm) |
|---------|--------|--------------|-------------|------------|-------------|
| UYV 20  | 6,30   | 3/4"         | 110,00      | 83,00      | 63,00       |
| UYV 25  | 10,00  | 1"           | 110,00      | 83,00      | 63,00       |
| UYV 32  | 16,00  | 1 1/4"       | 130,00      | 94,00      | 88,00       |
| UYV 40  | 25,00  | 1 1/2"       | 130,00      | 94,00      | 88,00       |
| UYV 40  | 25,00  | DN40 Flange  | 180,00      | 150,00     | 150,00      |
| UYV 50  | 40,00  | DN50 Flange  | 180,00      | 165,00     | 165,00      |
| UYV 65  | 63,00  | DN65 Flange  | 200,00      | 185,00     | 185,00      |
| UYV 80  | 100,00 | DN80 Flange  | 230,00      | 200,00     | 200,00      |
| UYV 100 | 160,00 | DN100 Flange | 260,00      | 220,00     | 220,00      |

### Product Description

- In our broad assortment of products, we are distributing and supplying a qualitative of Three Way Valve Actuators..



### Features:

- 3 way valves can be piped for diverting or mixing valve applications in domestic central heating and/or cooling systems
- Both versions can be used to control individual fan coil, baseboard radiator or convector applications
- Flanged control ball valve offering available (VBF)
- Accurate flow control
- Simplified actuator selection with a large range of Cvs
- Field replaceable stem allows valve to be serviced and replaced on the pipe
- Parabolic flow insert constructed into the ball provides high quality seals and precise control
- Multi-actuator mounting bracket allows the same bracket to be utilized on all valves
- Removable manual operating handle to control valve during installation or in an event of power failure

# Remote control Valve (dn20 to DN200)

( RFID Card / GSM / RF / LoRa / Wifi )

## Application:

- Battery Powered
- AMR Compatible
- Up to DN200
- Flanged connection
- Low pressure drop
- Can be used drinking water
- RFID Card / GSM / RF / LoRa / Wifi Optional
- Easy to use
- ATLAS Remote control Valves are used on the purpose of on/ off and regulation. This larger actuator area difference produces bigger control forces than required to close the valve, stopping the flow to the zero-flow condition. This larger actuator area difference produces bigger control forces than required to close the valve, stopping the flow to the zero-flow condition
- There are two kinds of valves available;
- Motor Actuated – Diaphragm Controlled Valves ( DN15 to DN40 )
- Diaphragm Actuated – Plug Controlled Valves ( DN50 to DN300 )

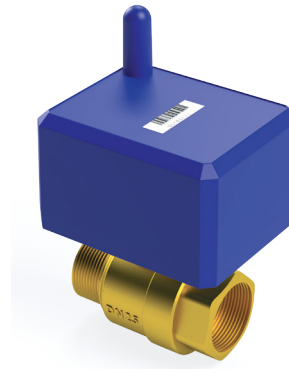
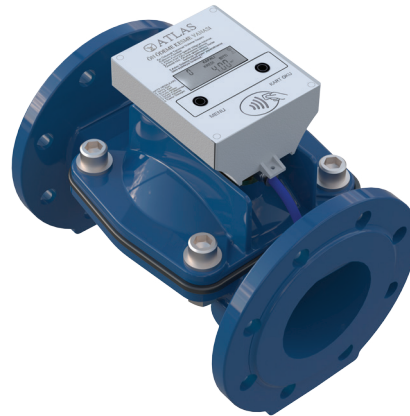

## Features:

- On/ off
- Pressure Reducing
- Pressure Sustaining (preserve) and Relief
- Pump Control (Automation to give and cut path)
- Surge Anticipating Control
- Solenoid Control (SCADA and Automation applications)
- Water Level Control (Modulating and Differential)
- Combinations of the above control valves (E.g. Pump Control Valve with Pressure Sustaining, Pressure Reducing Solenoid Valve)

# Ball Valve

## Application:

- ATLAS ball valve is a device with a spherical closure unit that provides on/off control of flow. The sphere has a port, also known as a bore, through the center. When the valve is positioned such that the bore is aligned in the same direction as the pipeline, it is in open position and fluid can flow through it. When rotated 90 degrees, the bore becomes perpendicular to the flow path, meaning the valve is closed and the fluid cannot pass through.

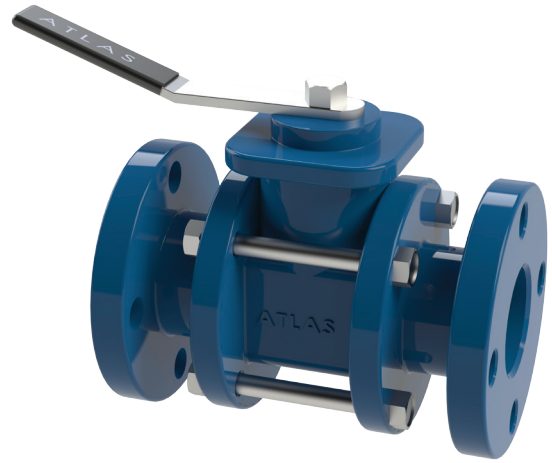

| Type | Flange Diameter [mm] | Torque [Nm] | Kvs [m <sup>3</sup> /h] | DN [mm] | Length [mm] | Height [mm] |
|------|----------------------|-------------|-------------------------|---------|-------------|-------------|
| 50   | 165                  | 12          | 310                     | 50      | 150         | 130         |
| 65   | 185                  | 30          | 600                     | 65      | 170         | 145         |
| 80   | 200                  | 35          | 950                     | 80      | 180         | 155         |
| 100  | 220                  | 45          | 1630                    | 100     | 190         | 180         |

## Features:

- Ball valve body made GJS 400 cast iron.
- It can be mounted to circulation pump by directly.
- It can be used in both directions.
- It has minimum pressure lose.
- It can be controlled by low torque.
- It can be used with gear box or actuator.

# Gate Valve

## Application:

- Gate valves are designed for fully open or fully closed service. They are installed in pipelines as isolating valves, and should not be used as control or regulating valves. Operation of a gate valve is performed doing an either clockwise to close or clockwise to open rotating motion of the stem. When operating the valve stem, the gate moves up- or downwards on the threaded part of the stem.



| Type   | D [mm] | Length [mm] | Height [mm] |
|--------|--------|-------------|-------------|
| DN 50  | 165    | 150         | 200         |
| DN 65  | 185    | 170         | 225         |
| DN 80  | 200    | 180         | 256         |
| DN 100 | 220    | 180         | 285         |
| DN 125 | 250    | 200         | 330         |
| DN 150 | 285    | 210         | 375         |
| DN 200 | 340    | 230         | 470         |
| DN 250 | 395    | 250         | 650         |
| DN 300 | 445    | 270         | 720         |

## Features:

- Gate valves are often used when minimum pressure loss and a free bore is needed.
- When fully open, a typical gate valve has no obstruction in the flow path resulting in a very low pressure loss.
- As the valve has to turn multiple times to go from open to closed position, the slow operation also prevents water hammer effects.

# AC frequency Converters

■ AT series inverter, presented by Atlas, is a new-generation high performance modular inverter that represents the future development of inverter. Compared with the traditional inverter, it satisfies the requirements of customers on performance and functions by a customized platform instead of several series of products that may increase the cost of manufacturing, sales, application and maintenance. This platform is established on the basis of the segmentation of the customer requirements, on which the modular design is conducted through the flexible combination of several modules of single series of products



Modbus-RTU, PROFIBUS-DP, CANlink and CANopen

| Model    | Phase | Adaptable Motor [kW] |
|----------|-------|----------------------|
| AT1PH220 | 1     | 0,4-2,2              |
| AT3PH220 | 3     | 0,4-75               |
| AT3PH380 | 3     | 0,75-400             |

## Product Features:

- Multiple voltage classes It provides coverage of single-phase 220 V, three-phase 220 V, three-phase 380 V, three-phase 480 V, three-phase 690 V and three-phase 1,140 V.
- Multiple output power 0.4KW to 630Kw
- Control of asynchronous motor and PMSM It supports vector control of three-phase AC asynchronous motor and three-phase AC PMSM
- Diversified control modes It supports three control modes, namely, sensorless flux vector control (SFVC), closedloop vector control (CLVC) and V/F control.
- Multiple communication protocols It supports communication via Modbus-RTU, PROFIBUS-DP, CANlink and CANopen.
- Multiple encoder types It supports various encoders such as differential encoder, open-collector encoder, resolver and UVW encoder.
- All-new SFVC algorithm It introduces an all-new sensorless flux vector control (SFVC) algorithm that gives better low-speed stability, enhanced low-frequency loading capacity, and supports torque control.
- Advanced background software The background monitoring software helps to achieve functions of parameter upload & download and a real-time oscilloscope.



# Temperature Sensors ( PTC NTC Pt100, Pt1000, Pt500)

## Applications:

- Atlas produced temperature sensors as your requirement in pocket, thermowell or head assemblies. All our thermocouple inserts are custom made, as such we are able to tailor your sensors exactly to your requirements.
- We can make temperature sensors using:
  - Pt100/Pt500/Pt1000 and other types of platinum resistance thermometer
  - Integrated Circuit (IC) Temperature Sensor (You supply or designate sensor to use)
  - Thermocouples – All types including base metal and rare metal
  - Thermistors ( NTC, PTC )
- OEM/ ODM services are welcome.
- Surface : as per your requirements
- Material : steel/aluminium/brass/iron/zinc
- Any other materials and dimensions depends on customers demand

## What we can do:

- Provide input on design for manufacturing
- Evaluate and explain the impact of design changes
- Explain the key manufacturing process of product performance parameters
- Contribute to trade-off analyses and problem solving
- Help you bring unit costs down
- Handle assembly of sensors from one-offs to millions of units
- Help you decide on the best technology to use whether it be resistance thermometers or thermocouples

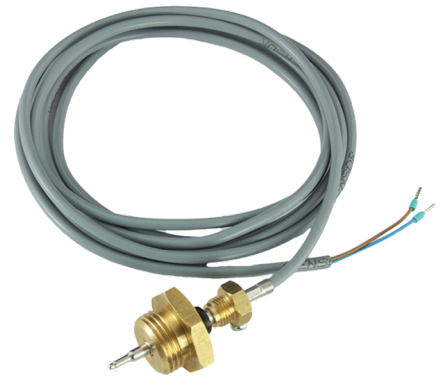



Erciyes Teknopark 4 Nolu Bina No. 67/48  
Melikgazi / KAYSERİ / TURKEY

---

[www.atlassayac.com](http://www.atlassayac.com)